

CODICE/CODE: ZNC120084

Batteria sigillata AGM (non adatta per impieghi ciclici)
AGM maintenance free battery (not DEEP-CYCLE)



Volt		12V
Capacity/capacità (20h)		120Ah
Capacity/capacità 25°C	10h	109Ah
	5h	98Ah
	1h	70.7Ah
Internal Resistance	Full Charged Battery 25°C	≤5mΩ
Capacity affected by Temperature	40°C	102%
	25°C	100%
	0°C	85%
Self-Discharge 25°C Capacity	after 3 month storage	90%
	after 6 month storage	80%
	after 12 month storage	62%
Charge (Constant Voltage) 25°C	Float	13.6-13.8Volt
	Charge	Max. 35Amp. 14.4-14.9Volt

Battery Dimensions/ Dimensioni batteria	L/L	331mm
	W/P	171mm
	H/A	214mm
	Tot- H/A	219mm
Box Dimensions/ Dimensioni scatola	L/L	346mm
	W/P	188mm
	H/A	289mm
Weight/peso		32Kg
Terminal/terminale		M8
Case/contenitore		ABS

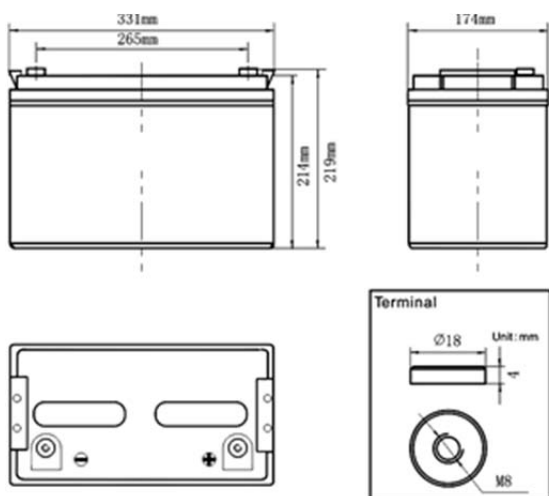

Temperature effect on float life

Float charging voltage ± 0.01V (25°C)

