

CODICE/CODE: ZTB060115A

Batteria al piombo ad acido libero, DEEP-CYCLE (uso ciclico)
Flooded DEEP-CYCLE battery



Volt		6V
Capacity/capacità 25°C	20h	235Ah
	5h	195Ah
Capacity affected by Temperature/Effetti della temperatura sulla capacità	40°C	102%
	25°C	100%
	10°C	80%
	0°C	60%
Self-Discharge 25°C Capacity / Autoscarica a 25°C	after 1 month storage	90%
	after 2 month storage	75%
	after 3 month storage	60%
Charge cycle/ Ciclo di carica	Wa	"I": max. 35Amp, min. 25Amp
	IWa	"In": max. 30Amp, min. 20Amp

Battery Dimensions/ Dimensioni batteria	L/L	260mm
	W/P	178mm
	H/A	289mm
	USA type	GC125
Weight/peso		31Kg
Electrolyte/elettrolita		7.29Lt
Pcs per pallet /pz. per pallet		32
Terminal/terminal		DT
Case/contenitore		PP

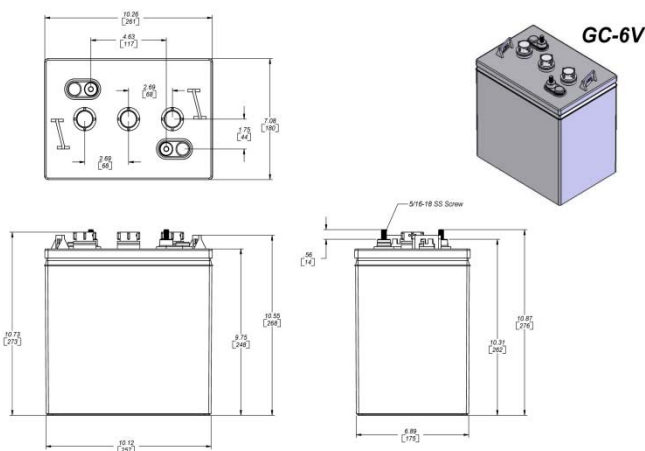
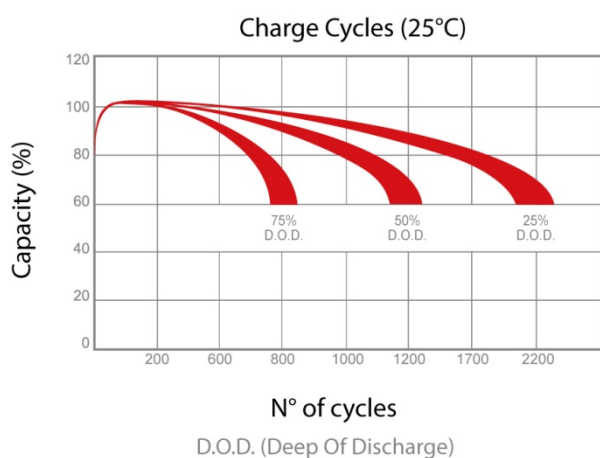

Ciclo di carica "IWa" – "IWa" charge cycle

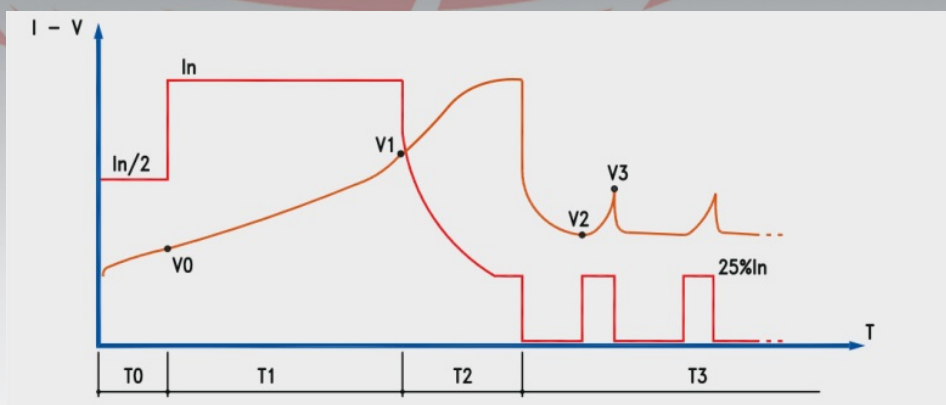

Ciclo di carica "Wa" – "Wa" charge cycle

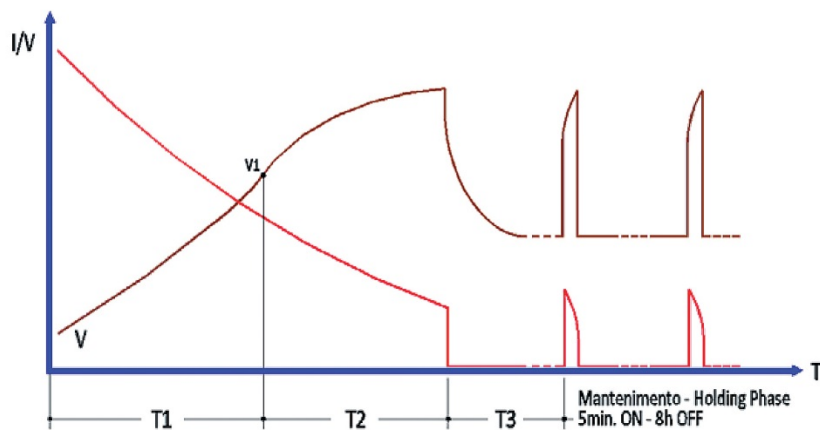

DUAL TERMINAL (DT)